

# Mast and Antennas for Field Day & Emergencies

John A. Allocca, WB2LUA, July 2005

This is a 27 feet 1.5" diameter portable guyed mast with a 28 feet diameter footprint. It breaks down into four 6 feet sections plus the tripod. The total weight of the mast and tripod is 15 pounds. The homemade 1/4 wave dipole antenna weighs 3 pounds. The Cushcraft D3 antenna weighs 9 pounds. The mast can rotate even when guyed because of the special slip ring that is constructed.

## Mast Construction - Step 1

Cut the 1/8" x 4" x 12" aluminum plate to 1/8" 4" x 4". Drill a 1.75" hole in the center. Drill 3/8" holes as shown in Figure 1 and figure 2. File all burrs.

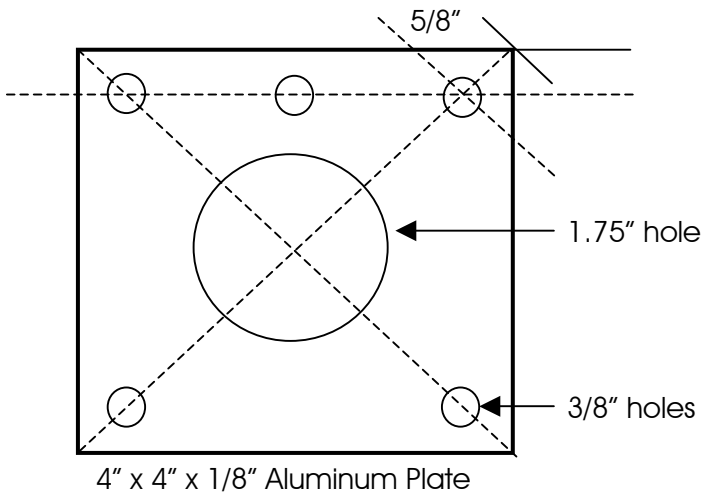

Figure 1

## Mast Construction - Step 2

Position the nylon shaft collar and tighten the set screw. Remove the set-screw and drill a 9/32" hole at the mark. Re-insert the set-screw and tighten. Add the nylon washer and silicon grease as shown in figure 3. Add the second nylon shaft collar and tighten the set screw. Remove the set-screw and drill a 9/32" hole at the mark. Add the 4" x 4" plate. Re-insert the set-screw and tighten as shown in figure 4 and figure 5. Rings for the guy ropes will be placed on the guy ring later. Three or four rings and guy ropes can be used.

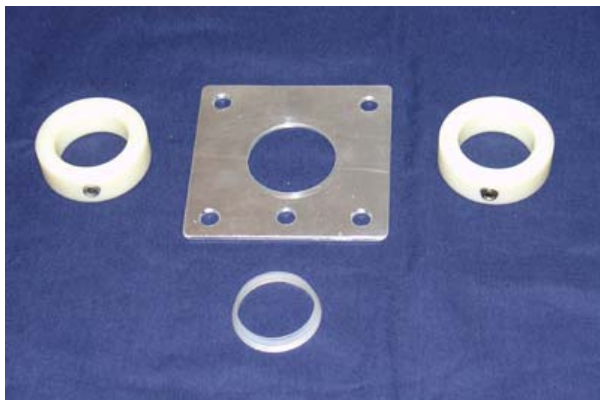

Figure 2

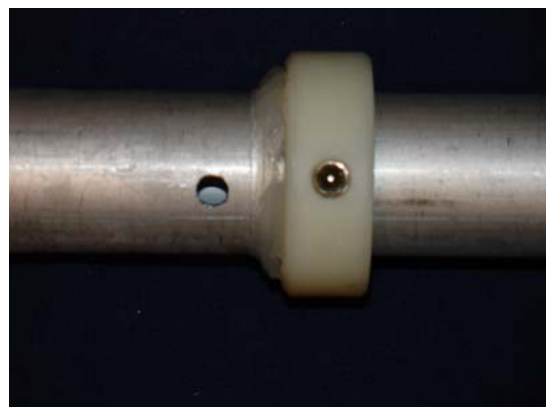

Figure 3

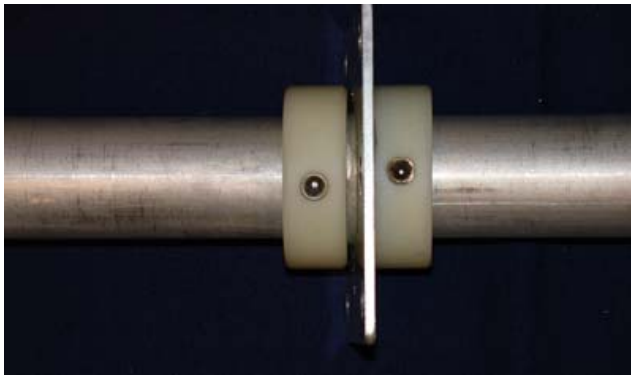

Figure 4



Figure 5

### Mast Construction - Step 3

Cut six 1.5" x 1.5" 90 degree aluminum pieces, 12 inches long. Drill four 5/16" holes, 1.5" and 4.5" from each end. Insert one 1.5" x 6 feet aluminum tube into the center. Drill 5/16" holes through the aluminum angles and through the aluminum tube as shown in figure 6. Place two 1/4-20 x 3" screws, washers and hex nuts through both pieces and tighten with a wrench. Repeat for the other end except use wing nuts in place of hex nuts so it can be disassembled easily. Repeat this process for the other two sections.

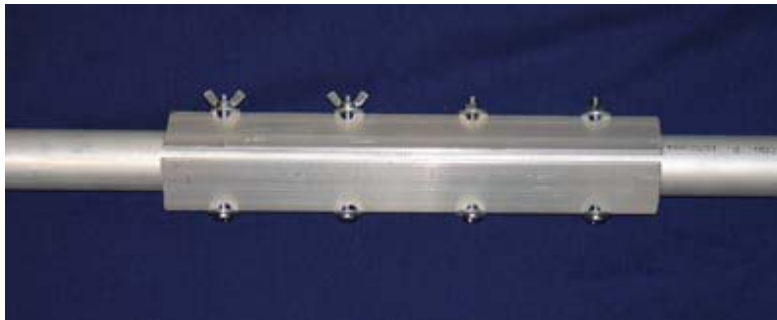

Figure 6

### Mast Construction - Step 4

Drill an 1 1/32" hole, 12 inches from the end of the bottom mast section so that the lock pin can be inserted as shown in figure 7.



Figure 7

## 1/4 Wave Dipole Antenna Construction

Cut a 21-inch length of 1.5" PVC pipe. Drill two 3/8" holes and insert coax cable, soldier lugs, bolt, lock washers, and 3/8-24 coupling nuts. Drill two 5/16" holes for mounting it to the mast as shown in figure 8. Drill a 1/4" hole on the bottom and secure the coax cable with a wire tire as shown in Figure 9 and figure 10. Drill holes in the top section of the mast so that the antenna can be attached. Tune two hamsticks with an antenna analyzer. Attach the two hamsticks to the coupling nuts.

### **1/4 Wave Dipole Antenna Test Results**

With the 20 meter dipole at a height of 24 feet, facing East and West from Northport, NY (altitude 187 feet), 5x9 reports were received from North Carolina, Georgia, Texas, and Pennsylvania. With the dipole facing North and South, 5x9 reports were received from as far as Argentina, South America. Propagation conditions were poor during this test (July 9, 2005).



Figure 8



Figure 9



Figure 10

## Finally Assembly

Assemble all components. Attach the guy rings and 1/4" nylon rope. Tighten the clamp on the tripod. Place a 6 feet piece of wood against the tripod legs so that it will not slip when the mast is hoisted upward. Attach either the 1/4 wave dipole antenna or the Cushcraft 1/2 wave D3 dipole antenna as shown in figure 13. Place three stakes in the ground 14 feet from the mast as show in figure 14. If the D3 antenna is used, have one person lift the antenna while another person pulls on the guy rope. Once the mast and antenna are in place, tighten the guy ropes. Loosen the clamp on the tripod so that the mast can rotate. Figure 12 shows the tripod. Figure 11 shows the mast and D3 antenna in place.



Figure 11



Figure 12



Figure 13



Figure 14

## Parts List – Mast

Custom-made - Slip Ring 4" x 4" x 1/8" aluminum, 1-3/8" hole in center, 3/8" holes for rings

(1) McMaster-Carr 9041K12 – 4" x 12" x 1/8" aluminum strip, \$8.13

(4) McMaster-Carr 3885T11 - Spring snap rings, 2.5" overall length, \$1.60 each

(4) McMaster-Carr 89965K751 - 1.5" OD, 1.37" ID (0.065" wall), aluminum tubing, 6' length, \$32.91 each

(1) McMaster-Carr 8982K23 – 1.5" x 1.5" 90 degree angle, 1/8" thick aluminum, 8' length, \$22.55

(1) McMaster-Carr 90272A554 - 1/4-20 x 3" zinc plated screws (box of 100), \$14.35

(1) McMaster-Carr 98970A129 - 1/4" zinc plated washers (box of 100), \$3.11

(1) McMaster-Carr 90480A029 - 1/4-20 zinc plated hex nuts (box of 100), \$2.28

(1) McMaster-Carr 90866A029 - 1/4-20 zinc plated wing nuts (box of 100), \$8.38

(1) McMaster-Carr 4807K275 – 1-1/2" pipe seal ring, \$2.63

(2) McMaster-Carr 60475K82 – 1-1/2" ID, 2.25" OD set screws nylon shaft collar, \$10.92 each

200 feet 3827T37 – 1/4" diameter twisted nylon rope, \$18.62

(1) On Stage Model SS7761B Reversible 1-1/2" – 1-3/8" Speaker Stand (the tubing must be 1.5" in diameter and removable), \$49.95

(5) CampMor 23504 - Heavy Galvanized Steel Hook Stakes - 18 inch, \$3.29 each

(1) 3/4" x 4" x 6' wood for the ground to hold the tripod in place.

Silicon grease

## Parts List – 1/4 Wave Antenna

2 - 20 meter or other Hamsticks (they must be tuned with an antenna analyzer)

1 – PL259 connector

1 – UHF female to female adapter

2 feet RG8X cable

(2) 3/8" Soldier lugs (ring terminals)

(1) McMaster-Carr 7113K814 - 3/8" hole ring terminals, package of 10, \$1.71

21" piece of 1-1/4" ID PVC pipe

(1) McMaster-Carr 43415K35 1.660 OD, 1.278" ID, 1-1/4" PVC pipe, 5' length, \$18.44

(2) McMaster-Carr 90264A470– 3/8-24 x 1-3/4" coupling nuts, \$0.82 each

(2) McMaster-Carr 90108A417 – 3/8 washers, package of 100, \$3.88

(2) McMaster-Carr 91102A760 – 3/8 lock washers, package of 100, \$2.11

(2) McMaster-Carr 92620A654 – 3/8-24 x 3/4" hex bolts, package of 25, \$4.28

(2) McMaster-Carr 90276A572 - 1/4-20, 4" screws, package of 100, \$9.38

(4) McMaster-Carr 98970A129 - 1/4" zinc plated washers (box of 100), \$3.11

(2) McMaster-Carr 90866A029 - 1/4-20 zinc plated wing nuts (box of 100), \$8.38